



TECHNICAL DATA

**3CPX5000A7
HIGH-MU
POWER TRIODE**

The 3CPX5000A7 is a ceramic/metal high-mu power triode designed for pulse applications. Utilizing beam-forming cathode and control grid geometry, this tube provides the gain of a tetrode with circuit advantages and simplified design of a triode. The attributes of high gain, low grid interception and outstanding intermodulation performance make this tube well suited for applications such as MRI and wind-profile radar service, or for pulsed linear amplifier service.

The 3CPX5000A7 is rated for pulsed rf amplifier service at a maximum plate voltage of 6500 Vdc. This tube is also useful in pulse modulator or pulse regulator service where accurately controlled waveforms are required; in this service the maximum rated plate voltage holdoff is 13 kVdc. The peak plate current rating in either service is 67 amperes.

The anode is forced-air cooled for 5000 watts of dissipation. The tube does not require a socket.

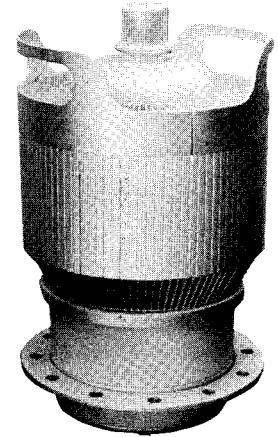

GENERAL CHARACTERISTICS ¹

ELECTRICAL

Cathode: Oxide Coated, Unipotential

Heater Voltage	15.0 ± 0.75 V
Heater Current, at 15.0 volts	15.0 A
Minimum Warmup Time (before application of rf drive and high voltage)	6 Min
Amplification Factor (approximate) ²	200
Direct Interelectrode Capacitance (grid grounded)	
C _{in}	92.5 pF
C _{out}	36.2 pF
C _{pk}	0.35 pF
Highest Frequency for Maximum Ratings (in Pulsed RF Service)	110 MHz

1. Characteristics and operating values are based on performance tests. These figures may change without notice as the result of additional data or product refinement. Varian EIMAC should be consulted before using this information for final equipment design.
2. Capacitance values are for a cold tube as measured with no special shielded fixture but otherwise in accordance with Electronic Industries Association Standard RS-191.

MECHANICAL

Maximum Overall Dimensions	
Length	8.25 in; 20.96 mm
Diameter	4.94 in; 12.55 mm
Net Weight	9.5 lb; 4.3 kg
Operating Position	Vertical, Base Up or Down
Cooling	Forced Air
Maximum Operating Temperature: Ceramic/Metal Seals or Anode Core	250°C
Base	Designed for Direct Chassis Mounting
Socket	None Required
Recommended Air Chimney	EIMAC SK-306
Available Anode Connector Clip, for DC, Pulse and LF/HF Applications	EIMAC ACC-3

PULSED RADIO FREQUENCY AMPLIFIER CATHODE DRIVEN Class B

ABSOLUTE MAXIMUM RATINGS:

DC PLATE VOLTAGE	6500 VOLTS
PEAK PLATE CURRENT #	67 AMPERES
DC PLATE CURRENT	3.75 AMPERES
PLATE DISSIPATION	5000 WATTS
DC GRID CURRENT	+0.10 AMPERE
INSTANTANEOUS GRID/CATHODE VOLTAGE	560 VOLTS
GRID DISSIPATION	25 WATTS

* Approximate value. # Average during the pulse.
¶ Estimated value.

TYPICAL OPERATION - Measured Data at 50 MHz Class B Cathode Driven - Du = 0.06

Plate Voltage	6400 Vdc
Cathode Bias Voltage	+80 Vdc
Pulse Plate Current #	16.25 Adc
Pulse Power Input #	104 kW
Pulse Grid Current * #	600 mA
Peak Driving Power * #	5.6 kW
Peak (Useful) Power Output # ¶	63 kW
Cathode Input Impedance	16.6 Ohms
Resonant Load Impedance	204 Ohms
Power Gain	10.5 dB

VA5058(Effective Sept 1988)

Printed in U.S.A.



PULSED RADIO FREQUENCY POWER AMPLIFIER
Cathode Driven, Class AB Service

ABSOLUTE MAXIMUM RATING:

DC PLATE VOLTAGE	6.5	KILOVOLTS
PEAK PLATE CURRENT #	67	AMPERES
DC PLATE CURRENT	3.75	AMPERES
PLATE DISSIPATION	5.0	KILOWATTS
DC GRID CURRENT	+0.1	AMPERE
GRID DISSIPATION	25	WATTS

- * Approximate value.
- # Average during the pulse.
- ¶ Power delivered to the load.

Note: 1/ Pulse duration, pulse plate current and duty are interrelated; see DERATING CHART on page 5.
 2/ To prevent excessive anode dissipation the tube must be cut off between pulses; a bias switching scheme should be employed to accomplish this. IMD is that of a similar product in CW service.

TYPICAL PERFORMANCE, to 30 MHz (measured data)

Plate Voltage	5.5	6.0	Vdc
Zero-Signal Plate Current	0.5	0.75	Adc
Pulse Plate Current #	3.9	5.25	a
Cathode Bias	+33	+30	Vdc
Pulse Grid Current * #	30	40	ma
Peak Driving Power *	425	750	w
Pulse Power Output # ¶	14	20	kw
Power Gain	15	14.2	dB
Cathode Input Impedance	23	19	Ohms
Resonant Load Impedance	1100	600	Ohms
Intermodulation Distortion:			
3rd Order Products	-33	-30	dB
5th Order Products	-38	-35	dB

PULSE MODULATOR OR SWITCH TUBE SERVICE

ABSOLUTE MAXIMUM RATINGS:

DC PLATE VOLTAGE	13	KILOVOLTS
PEAK PLATE CURRENT #	67	AMPERES
PULSE DURATION & DUTY #	SEE DERATING CHART	
PLATE DISSIPATION	5	KILOWATTS
DC GRID VOLTAGE	-250	VOLTS
GRID DISSIPATION	25	WATTS
DC GRID CURRENT	+0.1	AMPERE

- * Approximate value.
- # Pulse duration, pulse plate current and duty are interrelated; See DERATING CHART on page 5.

TYPICAL OPERATION - Pulse Modulator Service

Plate Voltage	8.0	kVdc
Pulse Plate Current	50	a
Grid Bias Voltage	-110	Vdc
Pulse Positive Grid Voltage	240	v
Pulse Grid Current *	1.0	a
Pulse Duration	10	uSec
Duty	0.0006	
Pulse Driving Power *	350	w
Pulse Output Power *	300	kw
Pulse Output Voltage	6.0	kv

TYPICAL OPERATION values are obtained by actual measurement or by calculation from published characteristic curves. Adjustment of the rf drive voltage to obtain the specified plate current at the specified bias and plate voltage is assumed. If this procedure is followed, there will be little variation in output power when the tube is replaced, even though there may be some variation in grid current. The grid current which occurs when the desired plate current is obtained is incidental and may vary from tube to tube. This current variation causes no performance degradation providing the circuit maintains the correct grid/cathode voltage in the presence of the current variation.

A P P L I C A T I O N

MECHANICAL

MOUNTING - The 3CPX5000A7 should be mounted vertically, base up or down, and should be protected from vibration and shock. The tube is designed to be bolted directly to the chassis (by the grid flange) in equipment designed for dc and rf grounded grid circuit configuration. The mounting may be insulated for other circuitry. A flange with threaded holes is provided for a low-inductance cathode connection. A similar provision is made for the heater connection.

STORAGE - If a tube is to be stored as a spare it should be kept in its original shipping carton, with the original packing material, to minimize the possibility of handling damage.

COOLING - Forced-air cooling must be provided to maintain the anode core and seal temperatures at a safe operating temperature. Cooling data are shown for incoming cooling air at 25°C, 35°C and 50°C, summarizing the minimum requirements to limit tube temperatures to 225°C. The pressure drop figures are approximate.

Inlet Air Temperature = 25°C

<u>Sea Level</u>	Plate Diss. Watts	Flow Rate CFM	Press. Drop In. Water
	2000	30	0.1
	3000	65	0.3
	4000	115	0.8
	5000	210	2.2
<u>5000 Feet</u>	Plate Diss. Watts	Flow Rate CFM	Press. Drop In. Water
	2000	35	0.1
	3000	75	0.3
	4000	140	0.9
	5000	220	2.0
<u>10,000 Feet</u>	Plate Diss. Watts	Flow Rate CFM	Press. Drop In. Water
	2000	45	0.1
	3000	95	0.4
	4000	165	1.0
	5000	265	2.3



Inlet Air Temperature = 35°C

<u>Sea Level</u>	<u>Plate Diss. Watts</u>	<u>Flow Rate CFM</u>	<u>Press. Drop In.Water</u>
	2000	35	0.1
	3000	75	0.3
	4000	130	0.9
	5000	180	1.7

<u>5000 Feet</u>	<u>Plate Diss. Watts</u>	<u>Flow Rate CFM</u>	<u>Press. Drop In.Water</u>
	2000	40	0.1
	3000	90	0.4
	4000	160	1.1
	5000	255	2.5

<u>10,000 Feet</u>	<u>Plate Diss. Watts</u>	<u>Flow Rate CFM</u>	<u>Press. Drop In.Water</u>
	2000	50	0.1
	3000	105	0.4
	4000	190	1.3
	5000	305	3.0

Inlet Air Temperature = 50°C

<u>Sea Level</u>	<u>Plate Diss. Watts</u>	<u>Flow Rate CFM</u>	<u>Press. Drop In.Water</u>
	2000	40	0.1
	3000	90	0.5
	4000	165	1.3
	5000	260	3.1

<u>5000 Feet</u>	<u>Plate Diss. Watts</u>	<u>Flow Rate CFM</u>	<u>Press. Drop In.Water</u>
	2000	50	0.1
	3000	110	0.5
	4000	200	1.6
	5000	315	3.7

<u>10,000 Feet</u>	<u>Plate Diss. Watts</u>	<u>Flow Rate CFM</u>	<u>Press. Drop In.Water</u>
	2000	60	0.2
	3000	135	0.6
	4000	240	1.8
	5000	385	4.3

It is considered good engineering practice to design for a maximum anode core temperature of 225 °C, and temperature-sensitive paints are available for checking base and seal temperatures before any design is finalized. It is also considered good practice to allow for variables such as dirty air filters, rf seal heating, and the fact that the anode cooling fins may not be clean if the tube has been in service for some length of time.

EIMAC Application Bulletin #20 titled TEMPERATURE MEASUREMENTS WITH EIMAC POWER TUBES discusses this subject and is available on request.

Forced air cooling of the base is also required, with air directed past the seal areas. An air interlock system should be used to automatically remove all voltages from the tube in case of even partial failure of the tube cooling air. Air flow must be applied before or simultaneously with the application of power, including the tube heater, and should normally be maintained for several minutes after power is removed for tube cooldown.

ELECTRICAL

ABSOLUTE MAXIMUM RATINGS - Values shown for each type of service are based on the "absolute system" and are not to be exceeded under any service conditions. These ratings are limiting values outside which serviceability of the tube may be impaired. In order not to exceed absolute ratings the equipment designer has the responsibility of determining an average design value for each rating below the absolute value of that rating by a safety factor so the absolute values will never be exceeded under any usual conditions of supply-voltage variation, load variation, or manufacturing variation in the equipment itself. It does not necessarily follow that combinations of absolute maximum ratings can be attained simultaneously.

HIGH VOLTAGE - Normal operating voltages used with this tube are deadly. Equipment must be designed properly and operating precautions must be followed. Design equipment so that no one can come in contact with high voltages. Equipment must include safety enclosures for the high-voltage circuits and terminals, with interlock switches to open primary circuits of the power supply and to discharge high-voltage capacitors whenever access doors are opened. The interlock switches must not be bypassed or "cheated" to allow operation with access doors open. Remember HIGH VOLTAGE CAN KILL.

For pulse modulator or regulator service anode voltage should not exceed 13 kVdc at sea level. This value assumes some safety factor and assumes a clean tube with no buildup of dirt or grime across the insulating ceramic. At higher altitudes a reduction in voltage may be required to preclude the possibility of external tube flashover.

HEATER/CATHODE OPERATION - Rated heater voltage for the 3CPX5000A7 is 15.0 volts, as measured at the base of the tube, and short-term variations should be limited to plus/minus 0.75 volt for good life and consistent performance.

Pulse current capability of the 3CPX5000A7 is dependent on cathode temperature, which in turn is dependent on heater voltage. For most consistent performance in switch tube or modulator service regulation of the heater voltage to limit variation to plus/minus one percent is recommended.

Heater voltage should be measured with a known accurate RMS-responding meter.

This tube is designed for normal commercial service, where one filament on/off cycle is anticipated per day. Contact EIMAC Application Engineering if more daily on/off cycles are expected.

CATHODE WARMUP/COOLDOWN TIME - It is recommended that heater voltage be applied for a minimum of 6 minutes before anode voltage and drive voltage are applied, to allow for proper conditioning of the cathode surface. It is also recommended that after all voltages are removed from the tube that air cooling be allowed to run for several minutes to allow for proper cooldown.

INPUT CIRCUIT - When operated as a grounded-grid rf amplifier, the use of a resonant tank in the cathode circuit is recommended to obtain greatest linearity and power output. For best results with a single-ended amplifier it is suggested the cathode tank circuit operate at a "Q" of 3 or more.



GRID OPERATION - The maximum rated dc grid bias voltage for the tube is -250 volts and the maximum grid dissipation is 25 watts. The maximum instantaneous positive grid voltage must not exceed 425 volts, and average grid current should never exceed 100 mAdc.

In normal applications the grid dissipation will not approach the maximum rating. In applications where pulse duration exceeds 100 Ms or duty factor is high, the electrode dissipation ratings may prevent attaining peak plate current substantially over the dc rating.

Oxide cathode tubes may exhibit reverse grid current. Protective circuitry for detection of overload and fault conditions should be capable of accepting current flow in either direction. This type of circuitry is necessary to prevent excessive grid dissipation and resulting tube degradation which can occur if proper output (plate) tuning or loading is lost due to failure in the tuned circuit or failure in the load.

A protective spark gap such as the Siemens #B1-C145 connected between the cathode and grid will help protect the tube in the event of an internal arc. A maximum of four (4) joules total energy may be permitted to dissipate into a grid-cathode arc. Amounts in excess of this will permanently damage the cathode or grid structure. Additional information is given in EIMAC Application Bulletin #17 titled FAULT PROTECTION, available on request.

CW OPERATION - Normal Class C operation is not permitted. Operation should be restricted to Class A, AB and B service. Operation in pulsed Class C is permissible only with low duty and short duration service.

ANODE CURRENT - For pulse service, either as a switch tube pulse modulator or voltage regulator, an anode current (during the pulse) of up to 67 amperes is available. Peak current capability, pulse duration, and duty factors are interrelated and the PULSE DERATING chart should be consulted. To use this chart, enter with pulse duration and note the intersection with the desired pulse anode current. At this intersection read off values of maximum duty and/or pulse repetition rate.

The pulse derating chart is intended to allow selection of operating parameters which give a reasonable tube life. Operating under experimental combinations of maximum plate current and pulse duration which are outside the ranges of the chart may give useful results at low repetition rates, with a resulting tube life commensurate with that type of operation.

New designs using tubes in pulse applications should include consideration of tube-to-tube performance variations which may effect equipment performance.

PLATE OPERATION - The anode of the 3CPX5000A7 is nominally rated for 5000 watts with forced-air cooling. In pulse service the average anode dissipation may be calculated as the product of pulse anode current, pulse tube-voltage drop during conduction, and the duty factor. Actual dissipation may often exceed the calculated value, if pulse rise and fall times are appreciable compared to pulse duration. This occurs because long rise and fall times allow plate current to flow for longer periods in the high tube-voltage drop region.

FAULT PROTECTION - All power tubes operate at voltages which can cause severe damage in the event of an arc, especially in cases where large amounts of power supply stored energy are involved. Some means of protection is advised in all cases, and it is imperative that a series resistor be used in the lead from the power supply to the anode circuit to limit peak current and help dissipate the energy in the event of a tube or circuit arc. A resistance of 10 ohms, with at least a 200W rating, in the positive plate power supply lead will help protect the tube in the event of an arc. A crowbar circuit which utilizes a high-speed switch tube is especially recommended for protection of the 3CPX5000A7 in pulse service.

Energy dissipated in the event of an arc must be limited to no more than 4 joules to prevent damage to the tube and consequential degradation in performance. EIMAC Application Bulletin #17 titled FAULT PROTECTION discusses this subject and is available on request.

VHF OPERATION - Operation at VHF should be conducted with heavy plate loading and the lowest drive power consistent with satisfactory performance. It is preferable to operate at a sacrifice in efficiency to obtain increased tube life. VHF driving power will be greater than the typical values shown on page 1 because of higher circuit losses.

INTERELECTRODE CAPACITANCE - The actual internal interelectrode capacitance of a tube is influenced by many variables in most applications, such as stray capacitance to the chassis, stray capacitance between tube terminals, and wiring effects. To control the actual capacitance values within the tube, as the key component involved, the industry and Military Services use a standard test procedure as described in Electronic Industries Association Standard RS-191. This test procedure eliminates any capacitance reading to "ground". The test is performed on a cold tube. Other factors being equal, controlling internal tube capacitance in this way normally assures good interchangeability of tubes over a period of time. The capacitance values shown in the technical data are taken in accordance with Standard RS-191. The equipment designer is therefore cautioned to make allowance for the actual capacitance values which will exist in his application. Measurements should be taken with the mounting which represents the approximate final layout if capacitance values are highly significant in the design.

RADIO-FREQUENCY RADIATION - Exposure to strong rf fields should be avoided, especially at frequencies above 300 MHz, where energy absorption by the human body is significant. The human eye is particularly sensitive. Prolonged exposure to rf radiation should be limited to 10 milliwatts per square centimeter (Occupational Safety & Health Administration (OSHA) standard). It is generally accepted that exposure to "high levels" of rf radiation can result in severe injury, including blindness. **CARDIAC PACEMAKERS MAY BE EFFECTED.**

SPECIAL APPLICATIONS - When it is desired to operate this tube under conditions widely different from those listed here, write to Varian EIMAC, attn: Product Manager, 301 Industrial Way, San Carlos, CA 94070 U.S.A.



OPERATING HAZARDS

PROPER USE AND SAFE OPERATING PRACTICES WITH RESPECT TO POWER TUBES ARE THE RESPONSIBILITY OF EQUIPMENT MANUFACTURERS AND USERS OF SUCH TUBES. ALL PERSONS WHO WORK WITH OR ARE EXPOSED TO POWER TUBES OR EQUIPMENT WHICH UTILIZES SUCH TUBES MUST TAKE PRECAUTIONS TO PROTECT THEMSELVES AGAINST POSSIBLE SERIOUS BODILY INJURY. DO NOT BE CARELESS AROUND SUCH PRODUCTS.

The operation of this tube may involve the following hazards, any one of which, in the absence of safe operating practices and precautions, could result in serious harm to personnel:

- a. HIGH VOLTAGE - Normal operating voltages can be deadly. Remember that HIGH VOLTAGE CAN KILL.
- b. LOW-VOLTAGE HIGH-CURRENT CIRCUITS - Personal jewelry, such as rings, should not be worn when working with heater contacts or connectors as a short circuit can produce very high current and melting, resulting in severe burns.
- c. RF RADIATION - Exposure to strong rf fields should be avoided, even at relatively low frequencies. The dangers of rf radiation are more severe at UHF and microwave frequencies and can cause serious bodily and eye injuries. CARDIAC PACEMAKERS MAY BE EFFECTED.
- d. HOT SURFACES - Surfaces of tubes can reach temperatures of several hundred °C and cause serious burns if touched for several minutes after all power is removed.

Please review the detailed operating hazards sheet enclosed with each tube, or request a copy from: Varian EIMAC, Power Grid Application Engineering, 301 Industrial Way, San Carlos CA 94070.

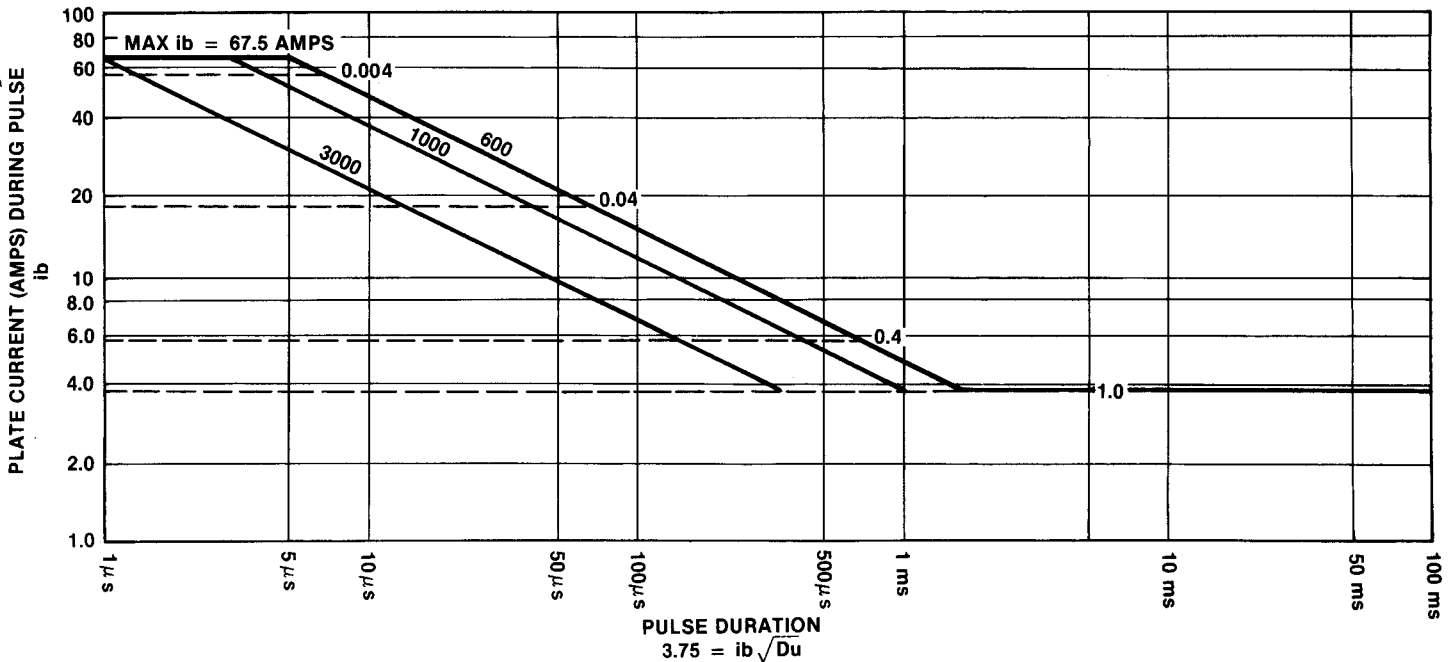

PULSE DERATING CHART, PULSE MODULATOR OR REGULATOR SERVICE

Solid lines represent constant repetition rates. Dashed lines represent constant duties. Do not extrapolate above or to the right of bold lines which set boundaries of maximum anode current and minimum repetition rate, respectively. Refer to section ANODE CURRENT on Page 4 for discussion of this chart.



3CPX5000A7

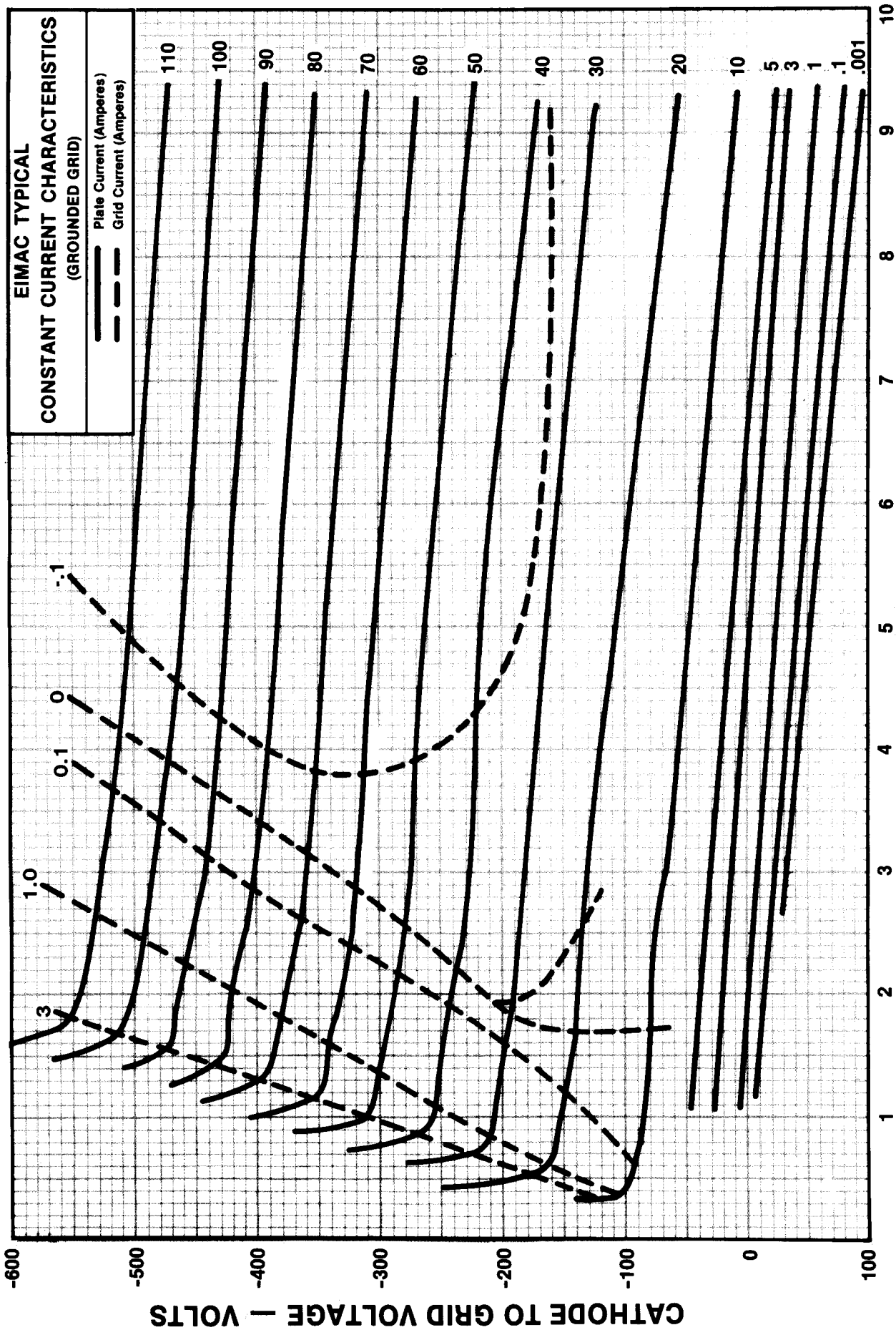

CURVE #5625

PLATE TO GRID VOLTAGE — KILOVOLTS

DIM.	INCHES			MILLIMETERS		
	MIN.	MAX.	REF.	MIN.	MAX.	REF.
A	4.812	4.938		122.22	125.43	
B	.866	.895		21.72	22.73	
C	.800	.780		16.24	19.30	
D	1.800	1.036		48.18	40.17	
E	2.805	2.935		73.53	74.55	
F	4.425	4.445		112.40	122.90	
G	6.030	6.080		127.78	129.29	
H			.265			6.73
J	8.017	8.267		203.83	209.88	
K	3.925	4.299		99.70	109.19	
L	3.223	3.697		81.86	91.30	
M	2.925	3.299		74.30	83.79	
N	.093	.166		2.38	3.96	
P			.125			3.18
R	.721	.845		18.31	21.48	
S	.375			9.53		
T						
U						
V						
W						
X						
Y						
Z						

NOTES:

1. REF DIMENSIONS ARE FOR INFO ONLY & ARE NOT REQUIRED FOR INSPECTION PURPOSES.
2. (*) CONTACT SURFACE

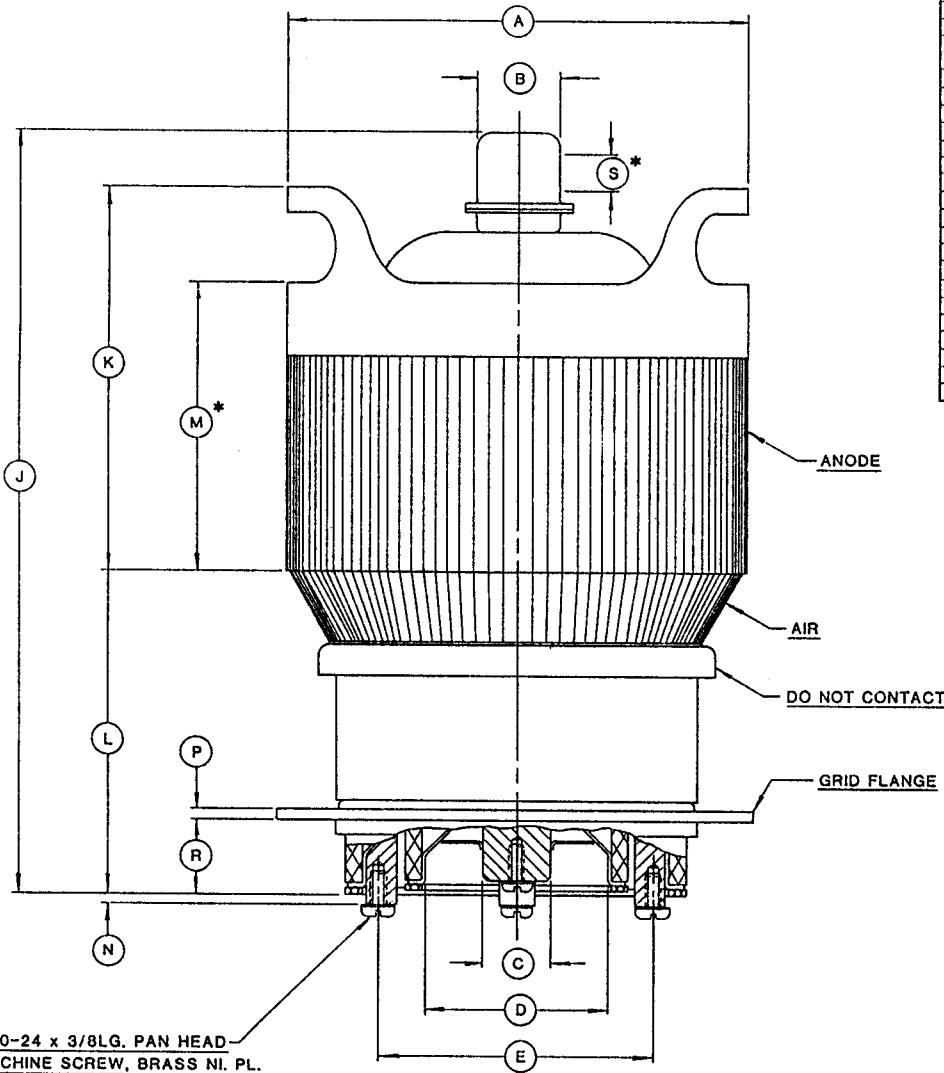

#10-24 x 3/8LG. PAN HEAD
 MACHINE SCREW, BRASS NI. PL.
 & #10 LOCKWASHER INTERNAL
 TOOTH BR. NI. PL.
 (5 EACH SUPPLIED)

